

Solid State Relays

Low Electromagnetic Noise Emission

Types RA 24.. -D 06 L, RA 40.. -D 08 L



- AC Solid State Relay
- Zero switching
- For ohmic load applications
- Rated operational current: 10 and 25 AACrms
- Rated operational voltage: Up to 400 VACrms
- 10 A type meets CISPR 22 B requirements

Product Description

This relay is designed for use in applications where low electromagnetic emission is essential.

Today, household and electrical appliances, information technology and medical equipment must conform with the latest EN standards. These new EN standards define general and product related requirements for noise immunity and noise emission. The RA24..-D06L and RA40..-D08L are relays for applications where the noise emission must be low and where the customer does not want

to relinquish all Solid State Relay features. The relay is available with zero crossing function. It is designed for resistive loads, i.e. power factor = 1.

Predestined applications for this relay are office machines, ovens and cookers for domestic and industrial use, theatre or stage lighting systems, film processing and copying machines or medical equipment.

Ordering Key

RA 24 25 -D 06 L

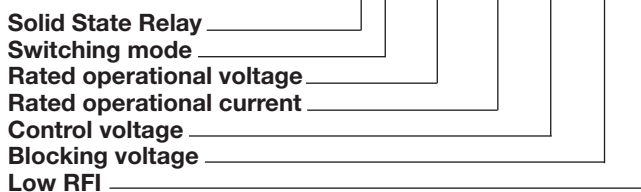

Type Selection

Switching mode	Rated operational voltage	Rated operational current	Control voltage	Blocking voltage	Electromagnetic noise emission
A: Zero switching	24: 230 VACrms 40: 400 VACrms	10: 10 AACrms 25: 25 AACrms	-D: 3 to 32 VDC	06: 650 V _p 08: 850 V _p	L: Low RFI

Selection Guide

Rated operational voltage	Blocking voltage	Electromagnetic noise emission	Control voltage	Rated operational current	
				10 AACrms	25 AACrms
230 VACrms	650 V _p	Low RFI	3 to 32 VDC	RA 2410 -D 06 L	RA 2425 -D 06 L
400 VACrms	850 V _p	Low RFI	3 to 32 VDC	RA 4010 -D 08 L	RA 4025 -D 08 L

General Specifications

	RA 24.. -D 06 L	RA 40.. -D 08 L
Operational voltage range	180 to 265 VACrms	340 to 530 VACrms
Blocking voltage	≥ 650 V _p	≥ 850 V _p
Operational frequency range	45 to 65 Hz	45 to 65 Hz
Power factor	1	1
Approvals	UR, cUR, CSA	UR, cUR, CSA
CE-marking	Yes	Yes



Input Specifications

Control voltage range	3 to 32 VDC
Pick-up voltage	≤ 3 V
Drop-out voltage	≥ 1 V
Reverse voltage	≤ 32 VDC
Input impedance	1 kΩ
Response time	≤ 1/2 cycle

Insulation

Rated isolation voltage Input to output	≥ 4000 VACrms
Rated isolation voltage Output to case	≥ 4000 VACrms
Reference voltage	500 VACrms
Insulation meets VDE 0700 requirements	

Output Specifications

	RA ..10 -D 0. L	RA ..25 -D 0. L
Rated operational current AC 51	10 Arms	25 Arms
Min. operational current	1 Arms	2 Arms
Rep. overload current t=1 s	≤ 30 A _p	≤ 50 A _p
Non-rep. surge current t=20 ms	90 A _p	200 A _p
Off-state leakage current	≤ 1 mArms	≤ 1 mArms
I ² t for fusing t=10 ms	≤ 40 A ² s	≤ 200 A ² s
On-state voltage drop	≤ 1.2 Vrms	≤ 1.2 Vrms
Critical dV/dt off-state	≥ 250 V/μs	≥ 250 V/μs
Synchronization current	≤ 20 mArms	≤ 20 mArms

Thermal Specifications

	RA ..10 -D 0. L	RA ..25 -D 0. L
Operating temperature range	-20° to +70°C (-4° to +158°F)	-20° to +70°C (-4° to +158°F)
Storage temperature range	-40° to +100°C (-40° to +212°F)	-40° to +100°C (-40° to +212°F)
Junction temperature	≤ 125°C (257°F)	≤ 125°C (257°F)
R _{th} junction to case	≤ 2.5°C/W	≤ 1.8°C/W

Wiring Diagram

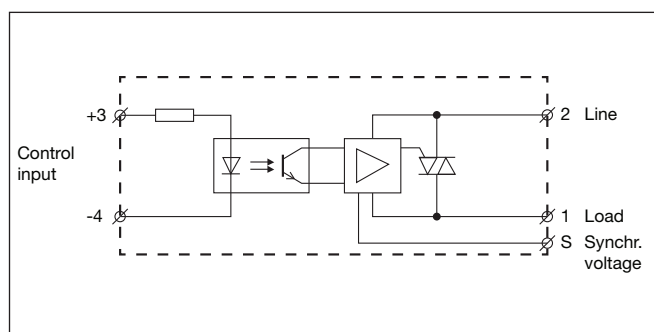

Functional Diagram

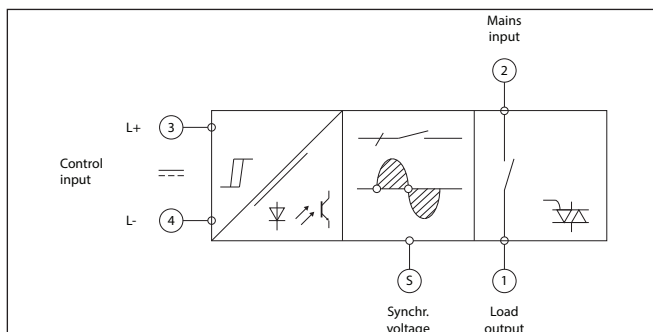



Heatsink Dimensions (load current versus ambient temperature)

RA ..10 -D 0. L

Load current [A]	Thermal resistance [°C/W]						Power dissipation [W]
	20	30	40	50	60	70	
10	5,7	5,0	4,3	3,6	2,8	2,0	14
9	6,2	5,4	4,6	3,9	3,1	2,2	12
8	7,4	6,4	5,5	4,6	3,7	2,7	11
7	8,5	7,4	6,3	5,3	4,2	3,1	9
6	9,8	8,6	7,4	6,1	4,9	4,9	8
5	-	10,2	8,7	7,2	5,8	6,2	7
4	-	-	10,5	8,7	7,0	5,7	6
3	-	-	-	10,7	8,5	4,7	5
2	-	-	-	-	10,8	8,1	4
1	-	-	-	-	-	10,7	3

T_A
Ambient temp. [°C]

RA ..25 -D 0. L

Load current [A]	Thermal resistance [°C/W]						Power dissipation [W]
	20	30	40	50	60	70	
25	1,0	0,8	0,5	0,25	-	-	38
22.5	1,5	1,1	0,8	0,5	0,26	-	33
20	1,9	1,6	1,2	0,9	0,5	-	29
17.5	2,5	2,1	1,7	1,3	0,9	0,5	25
15	3,3	2,9	2,4	1,9	1,4	1,0	21
12.5	4,4	3,9	3,3	2,7	2,1	1,5	17
10	5,7	5,0	4,3	3,6	2,9	2,1	14
7.5	7,5	6,6	5,6	4,7	3,7	2,8	11
5	10,6	9,3	8,0	6,6	5,3	4,0	8
2.5	-	-	-	10,7	8,5	6,4	5

T_A
Ambient temp. [°C]

Heatsink Selection

Carlo Gavazzi Heatsink (see Accessories)	Thermal resistance
No heatsink required	R _{th s-a} > 12,5 °C/W
RHS 100 Assy	3,0 °C/W
RHS 301 Assy	0,8 °C/W
RHS 301 F Assy	0,25 °C/W
Consult your distributor	< 0,25 °C/W

Compare the value found in the current versus temperature chart with the standard heatsink values and select the heatsink with the next lower value.

Accessories

Heatsinks
DIN rail adapter
Varistors
Fuses

For further information refer to "General Accessories".

Applications

The very low, wire-conducted RFI feature of this relay is obtained by synchronized firing of the output triac in the zero crossing of the mains voltage. Therefore the relay must have the synchronization input connected to the mains, either to neutral or to the phase depending on how the load is connected.

The relay can only switch resistive loads with a power factor of 1.

A minimal load current of 1A for the RA ..10 -D 0. L and 2 A for the RA ..25 -D 0. L is required as long as the control input is activated.

Connection Diagram

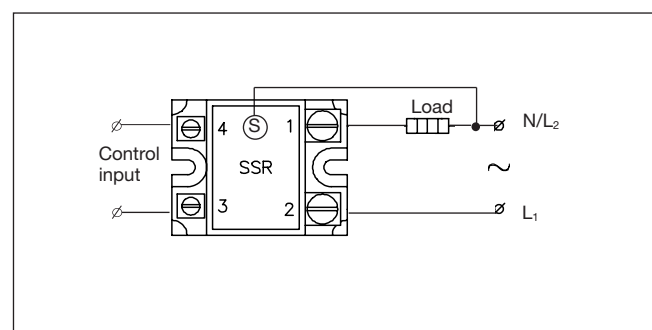



Dimensions

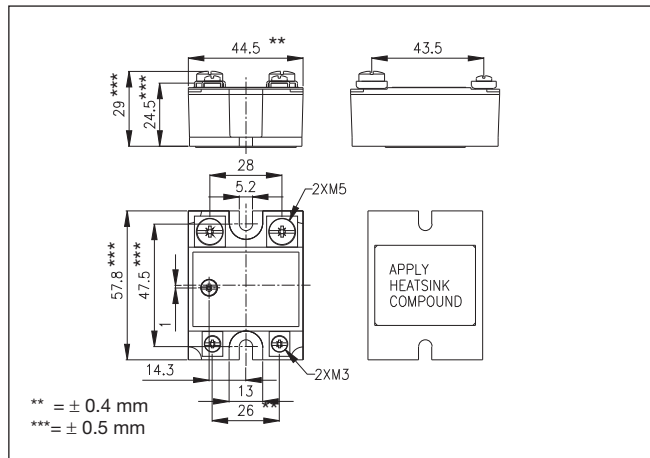

Housing Specifications

Weight	Approx. 110 g
Housing material	Noryl GFN 1, black
Base plate	Aluminium
Potting compound	Polyurethane
Relay	
Mounting screws	M5
Mounting torque	≤ 1.5 Nm
Control and Synchr. terminal	
Mounting screws	M3 x 6
Mounting torque	≤ 0.5 Nm
Power terminal	
Mounting screws	M5 x 6
Mounting torque	≤ 2.4 Nm

Connection Examples

RA24xx-D06L and RA40xx-D08L

3-phase application with two heat elements without ground.

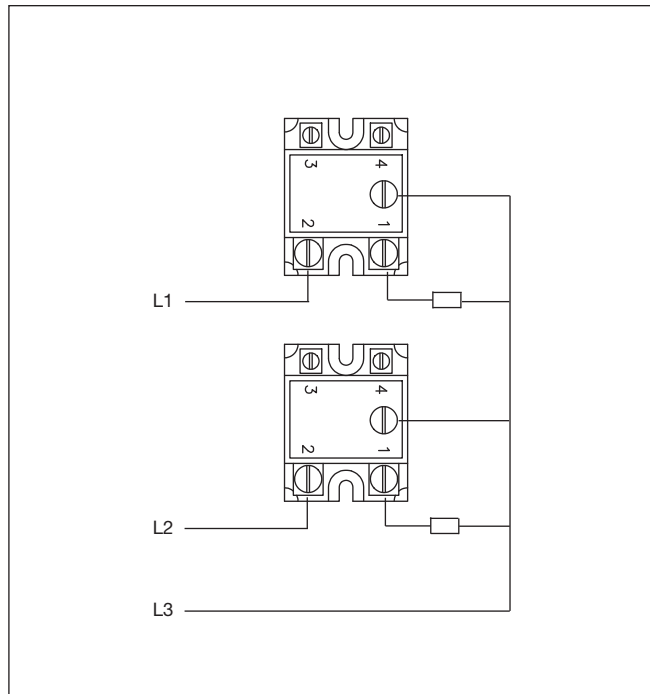

3-phase application with three heat elements.

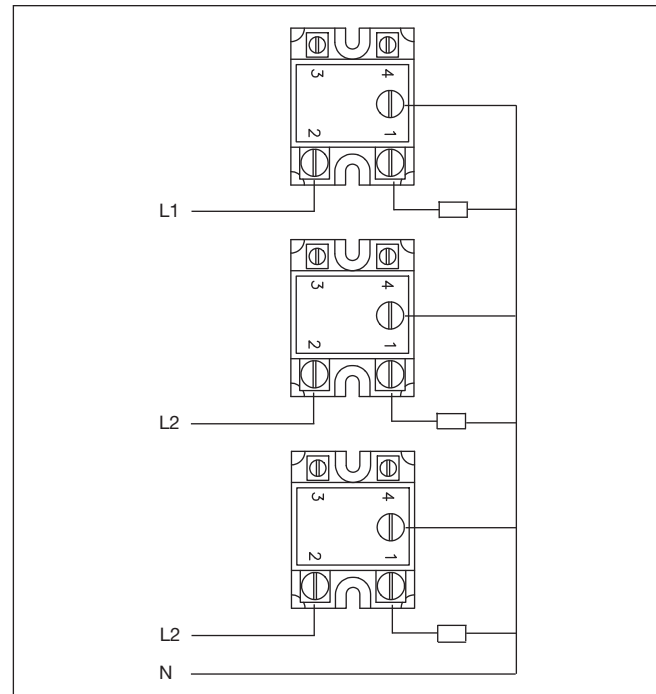

2-phase application with one heat element.

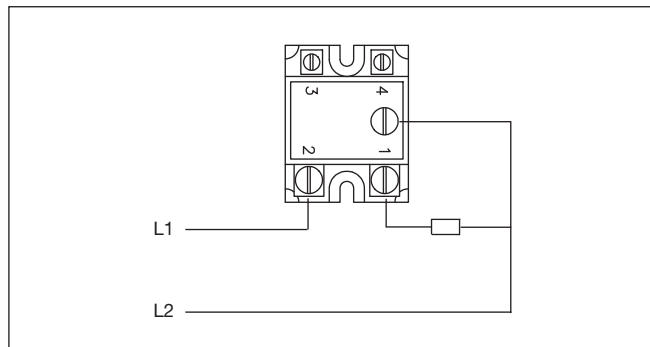

1-phase application without ground.

